



Dual discharge air coolers THOR-D

Standard coolers with Cu tubing





Contents

	page
Model indication	2
Eurovent	2
Capacities	2
General information	3
Standard product configuration	3
Non standard executions	4
Correction factors & Selection example	5
Capacities & technical data	6
Fans	8
Defrost systems	9
Dimensions	10

Model indication

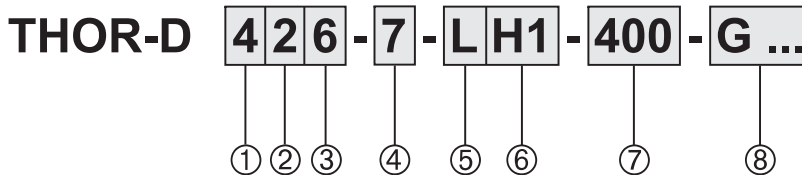

Pos.	Reference
1	Cooler module 2, 4 and 6
2	Number of fans 1 - 5
3	Tube rows 4, 6 or 8 tube rows in air direction
4	Fin spacing 4, and 7 mm
5	Fan speed L = low (1000 rpm) H = high (1500 rpm)
6	Circuiting design H1, H2 ...
7	Current 400 = 230/400/50/3 230 = 230/50/1
8	Options For a full survey of all available options see page 4

Eurovent

Within Europe, a wide variety of published data on capacities are in use, generally depending on national standards. Most in use by the leading manufacturers are national and international standards like DIN, ENV, NEN-EN and ASHRAE. Due to this, customers have not been able to make objective product comparisons, since data published on capacities were based on DT_1 , DTM , dry or wet conditions, with or without certification, etc.



To meet the European requirements on EN standards, the European Refrigeration Industry embodied by Eurovent has set standards to guarantee an independent certification procedure for forced convection air cooled condensers based on NEN-EN 327 and unit air coolers based on NEN-EN 328. Being an active member of Eurovent, the capacities of the Alfa Laval commercial cooler programme, as given in the technical documentation, are based on NEN-EN 328 (evaporating temperature $t_0 = -8\text{ °C}$, 8 K temperature difference between air-on temperature and evaporating temperature (DT_1)).

In order to enable air cooler selection for operating conditions, technical documentation should also give capacities for humid/frosted conditions. According to Eurovent these 'frosted conditions' are to be calculated by multiplying 'dry capacities' with a factor 1.15. These data can be found in the capacity tables, in the columns marked "frosted".

Capacities

Frosted conditions

- Lightly frosted coil.
- Relative humidity 85 %.
- Suction gas superheating 62% of the temperature difference (DT_1), with a minimum of 3.5 K.
- Refrigerant liquid temperature 30 °C (for $t_0 = -20\text{ °C}$ and below; liquid temperature 10 °C).

Evaporating temperature t_0

Evaporating temperature t_0 is the saturated temperature according to the pressure at the suction outlet of the cooler.

Dry conditions

Cooling capacity where no condensation or ice build-up occurs on the coil (100% sensible cooling). This condition is used by Eurovent to standardise capacity ratings but should not be used when selecting coolers. For cooler selection use the columns marked "frosted".

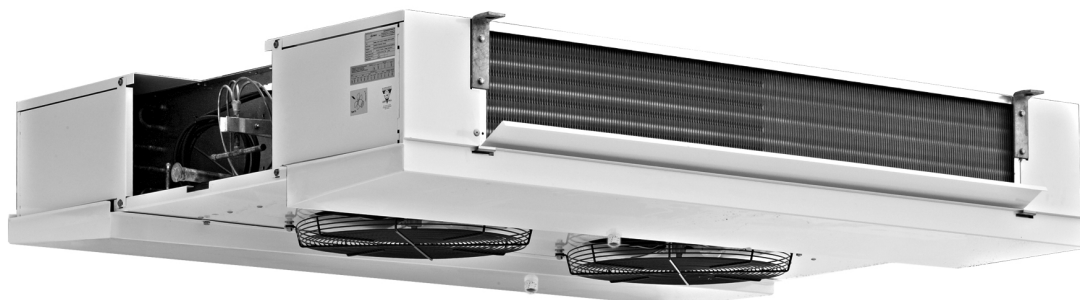

General Information

Dual discharge air coolers THOR-D are a further extension to the already wide and flexible THOR range of industrial air coolers. THOR-D dual discharge coolers are characterized by a low silhouette.

Application area: evaporating temperatures of +5 down to -40 °C using either halogen refrigerants, CO₂ or secondary refrigerants.

Capacities (Eurovent SC 2) 4,5 up to 116.1 kW.

Air flow 3,000 up to 60,000 m³/h.

Other THOR models

THOR

The THOR series is a wide and flexible range of industrial air coolers fitted with blow-through or draw-through fans. These models have been highly standardised in construction and dimensions, while maintaining flexibility in fin spacings, coil construction and circuiting design.



THOR-A

For airsock application Alfa Laval has developed a special airsock cooler range. These THOR-A models are fitted with an airsock ring and fan motors capable of supplying the extra external pressure that is required for the proper functioning of airsocks.



THOR-F

Air cooler models THOR-F have been optimized for the refrigerated storage of agricultural products. These cooler models are characterised by an optimised capacity / air volume ratio and a relatively low profile.



All THOR, THOR-D, THOR-F and THOR-A models are also available with stainless steel tubing (TYR range).

Two-Year Guarantee

Because Alfa Laval has the fullest confidence in the product quality, a two-year full guarantee is given.

Product Configuration

- Finned coil
 - 3 coil block modules
 - 4, 6 or 8 tube rows deep
 - Cu ripple fin tubing \varnothing 5/8" (smooth tubing for brine)
 - Tube pitch 50 x 50 mm square
 - Corrugated Alu-fins
 - Fin spacings 4, and 7 mm.
- 1-5 Fans, blowing through the coil, available in a range of different executions.
 - Diameters \varnothing 457, \varnothing 508 and \varnothing 560 mm.
 - Motor cables are led to the outside of the cooler casing.
 - Fan motors protection class IP55.
 - 1000 rpm = L design
 - 1500 rpm = H design
- Corrosion resistant casing material:
 - Aluminium/Sendzimir, white epoxy coated (RAL 9003).
- Hinged, enclosed endcovers.
- Hinged drip tray with vertical drains 1 1/4" BSP male.
- Refrigerant distribution optimised to refrigerant applied.
- Fitted with schrader valve on the suction connection for testing purposes.
- Sufficient room for fitting the expansion valve inside.
- Suitable for dry expansion or pumped system.
- Stickers indicate fan direction and refrigerant in/out.
- Delivery in mounting position. Coolers are mounted on wooden beams. Installation can take place with use of a forklift.
- Design pressure 33 bar (H(C)FC) or 6 bar (brine). Higher design pressures on request. Each heat exchanger is leak tested with dry air and finally supplied with a nitrogen pre-charge.



Options

■ Defrost systems

- Hot gas coil in driptray **G1**
- Electric defrost **E1, E4**
- Hot glycol defrost **HW1, HW2**

Electric defrost for air coolers with pumped refrigerant circulation or in glycol execution on special request only.

■ Fan ring heater **FRH**
■ Driptray insulation

- Styropore 10 mm + cladding **I 2**
not in combination with electric defrost
- Foamglass 25 mm + cladding **I 3**

■ Isolating switch (mounted) **ISM**
■ Horizontal drain

Hinged driptray with horizontal drain at the short side. Available for THOR-D up to 3 fans, but not in combination with driptray insulation I2.

■ Dual fan speed motors (Dahlander 1500/750)

Only available for modules 2 and 4.

For this fan motor all table values for cooling capacity and air volume need to be adjusted according to the following percentages:

Capacity	Module 2	Module 4
n = 1500 rpm	100 %	90 %
n = 750 rpm	60 %	50 %

Air flow	Module 2	Module 4
n = 1500 rpm	100 %	80 %
n = 750 rpm	50 %	40 %

■ Secondary refrigerant

Air coolers for secondary refrigerant application can be selected with our selection software. Extra information on request.

■ Stainless steel 304 casing **SSC**
■ Fan motors 400/60/3 or 230/60/1
Non-standard executions *(on request only)*
■ Higher capacities
■ Special fan motors:

- Dual fan speed motors
- Variable fan speed motors
- EC fans
- Alternative electrical supply 460/60/3

■ Built in heater coil sections

Fan Ring Heater (FRH, 230 Volt)

incl. mounting gear

Cooler module	Fan diameter mm	Ring heater power W
2	457	450
4	508	500
6	560	500

Driptray Insulation (I)

For specific operational conditions the air coolers can be fitted with driptray insulation.

Insulation of the driptray is recommended for air coolers with hot gas defrosting used at a room temperature below -5 °C. For areas with high relative humidity it may also be necessary to insulate other parts of the casing.

At extra cost this driptray insulation can be combined with the usual epoxy coating.

Note : When selecting driptray insulation the overall height "B" of the coolers (see page 10) increases by the thickness of the insulation material applied.

Dual discharge air coolers

THOR-D

Selection Example DT₁

Refrigerant	R-404A dx
Selected fin spacing	7 mm
Fan speed H	1500 rpm
Required cooling capacity	30 kW
Air-on temperature	+2 °C
Evaporating temperature	-5 °C

- 1) $DT_1 = +2 - (-5) = 7 \text{ K}$
- 2) Correction factor $DT_1 / R-404A : 1.15$
- 3) Multiply required capacity
with correction factor : $30 \times 1.15 = 34.5 \text{ kW}$.
- 4) Cooler models can be selected in column 'capacity/
frosted' with a nominal capacity of 34.5 kW.

For the above mentioned conditions the following models can be selected :

- THOR-D 246-7-H, nom. cap. 32.0 kW
- THOR-D 248-7-H, nom. cap. 39.4 kW
- THOR-D 428-7-H, nom. cap. 32.3 kW
- THOR-D 436-7-H, nom. cap. 39.9 kW
- THOR-D 444-7-H, nom. cap. 39.4 kW

Depending on parameters such as *air flow*, *number of fans* and *dimensions* (see tables) a final cooler model selection can take place.

Capacity values under 'dry conditions' are reference values for Eurovent conditions.

Standard condition SC	Air on temp. °C	Evaporating temperature °C	Factor dry/frosted
SC1	10	0	1.35
SC2	0	-8	1.15
SC3	-18	-25	1.05
SC4	-25	-31	1.01

SC 2 : Nominal capacity for cooling design.

Air-on temperature is the air temperature at the intake side of the coil block.

Correction factors

DT1 K	Evaporating temperature °C									
	+5	0	-5	-8	-10	-15	-20	-25	-30	-35
R-404A dx										
6	1.28	1.32	1.38		1.44	1.51	1.58	1.64	1.69	1.72
7	1.06	1.10	1.15		1.20	1.27	1.33	1.39	1.44	1.48
8	0.89	0.93	0.97	1.00	1.03	1.09	1.15	1.21	1.26	1.29
9	0.77	0.80	0.84		0.89	0.95	1.00	1.06	1.11	1.15
10	0.67	0.70	0.74		0.78	0.83	0.89	0.95	1.00	1.04
11	0.59	0.62	0.65		0.70	0.74	0.80	0.85	0.90	0.94
R-134a dx										
6	1.34	1.42	1.50		1.60	1.71	1.82	1.94		
7	1.11	1.17	1.25		1.34	1.43	1.54	1.64		
8	0.94	0.99	1.06		1.14	1.23	1.32	1.42		
9	0.81	0.86	0.92		0.99	1.07	1.16	1.25		
10	0.70	0.75	0.80		0.87	0.94	1.03	1.11		
11	0.62	0.66	0.71		0.77	0.84	0.92	1.00		
R-22 dx										
6	1.34	1.39	1.45		1.52	1.59	1.66	1.73	1.78	1.81
7	1.11	1.15	1.21		1.27	1.33	1.40	1.47	1.52	1.55
8	0.94	0.98	1.03		1.08	1.14	1.21	1.27	1.32	1.36
9	0.81	0.84	0.89		0.94	1.00	1.06	1.12	1.17	1.21
10	0.70	0.74	0.78		0.82	0.88	0.94	1.00	1.05	1.09
11	0.62	0.65	0.69		0.73	0.78	0.84	0.90	0.95	0.99
R-404A pumped system										
6	1.00	1.07	1.13		1.19	1.24	1.29	1.34	1.39	1.44
7	0.82	0.88	0.94		1.00	1.05	1.10	1.15	1.20	1.25
8	0.70	0.75	0.80		0.85	0.90	0.95	1.00	1.05	1.11
9	0.60	0.65	0.69		0.74	0.79	0.84	0.89	0.94	1.00
10	0.52	0.56	0.61		0.65	0.70	0.75	0.80	0.85	0.91
11	0.46	0.50	0.54		0.58	0.62	0.67	0.72	0.78	0.84
R-22 pumped system										
6	1.13	1.21	1.28		1.34	1.39	1.44	1.48	1.53	1.58
7	0.92	0.98	1.05		1.10	1.16	1.21	1.25	1.30	1.36
8	0.76	0.82	0.88		0.93	0.98	1.03	1.08	1.14	1.20
9	0.64	0.70	0.75		0.80	0.85	0.90	0.95	1.01	1.07
10	0.55	0.60	0.65		0.70	0.74	0.79	0.84	0.90	0.97
11	0.48	0.52	0.57		0.61	0.66	0.71	0.76	0.82	0.89

Correction factors for other refrigerants, alternative fin materials, coatings and optional coil block configurations on request.

Dual discharge air coolers

THOR-D

Technical data

Cooler model THOR-D	Capacities R-404A (kW)		Air flow m ³ /h	Coil surface m ²	Int. vol. dm ³	Weight kg	Dimensions		Fans			
	Frosted $t_0=-8^{\circ}\text{C}$ $DT_1=8\text{K}$	Dry cond. $t_0=-8^{\circ}\text{C}$ $DT_1=8\text{K}$					Length A mm	Height B mm	Cap. kW	Nr	Air throw (m)	Sound press. dB(A)
Execution H (n = 1500 rpm), fin spacing 4 mm												
214 - 4 - H	7.4	6.4	4750	46.0	10	95	1250	385	0.25	1	14	59
216 - 4 - H	9.7	8.4	4650	68.9	15	110	1250	385	0.25	1	14	59
224 - 4 - H	14.8	12.9	9500	91.9	18	155	2050	385	0.25	2	14	62
226 - 4 - H	19.3	16.8	9300	137.9	27	185	2050	385	0.25	2	14	62
234 - 4 - H	22.2	19.3	14250	137.9	27	220	2850	385	0.25	3	14	64
236 - 4 - H	29.0	25.2	13950	206.8	40	265	2850	385	0.25	3	14	64
244 - 4 - H	29.7	25.8	19000	183.9	35	280	3650	385	0.25	4	14	65
246 - 4 - H	38.6	33.6	18600	275.8	52	340	3650	385	0.25	4	14	65
254 - 4 - H	36.2	31.5	23750	229.8	43	340	4450	385	0.25	5	14	66
256 - 4 - H	48.8	42.5	23250	344.7	65	420	4450	385	0.25	5	14	66
414 - 4 - H	12.1	10.5	7950	76.6	16	135	1450	485	0.55	1	18	62
416 - 4 - H	16.1	14.0	7600	114.9	23	160	1450	485	0.55	1	18	62
424 - 4 - H	24.2	21.0	15900	153.2	30	220	2450	485	0.55	2	18	65
426 - 4 - H	32.2	28.0	15200	229.8	44	275	2450	485	0.55	2	18	65
434 - 4 - H	37.3	32.4	23850	229.8	44	315	3450	485	0.55	3	18	67
436 - 4 - H	47.4	41.2	22800	344.7	65	390	3450	485	0.55	3	18	67
444 - 4 - H	48.4	42.1	31800	306.4	57	405	4450	485	0.55	4	18	68
446 - 4 - H	64.3	56.0	30400	459.6	86	510	4450	485	0.55	4	18	68
454 - 4 - H	62.0	53.9	39750	383.0	71	500	5450	485	0.55	5	18	69
456 - 4 - H	79.4	69.0	38000	574.6	107	625	5450	485	0.55	5	18	69
614 - 4 - H	18.8	16.3	12200	114.9	24	184	1650	585	1.50	1	20	65
616 - 4 - H	24.2	21.0	11650	172.4	41	240	1650	585	1.50	1	20	65
624 - 4 - H	37.5	32.7	24400	229.8	44	346	2850	585	1.50	2	20	68
626 - 4 - H	48.4	42.1	23300	344.7	70	450	2850	585	1.50	2	20	68
634 - 4 - H	55.6	48.4	36600	344.7	65	506	4050	585	1.50	3	20	70
636 - 4 - H	73.1	63.6	34950	517.1	98	650	4050	585	1.50	3	20	70
644 - 4 - H	75.1	65.3	48800	459.6	87	663	5250	585	1.50	4	20	71
646 - 4 - H	96.8	84.3	46600	689.5	127	853	5250	585	1.50	4	20	71
654 - 4 - H	94.4	82.1	61000	574.6	108	820	6450	585	1.50	5	20	72
656 - 4 - H	116.1	101.0	58250	861.8	156	1055	6450	585	1.50	5	20	72
Execution H (n = 1500 rpm), fin spacing 7 mm												
214 - 7 - H	5.9	5.1	5070	27.0	10	85	1250	385	0.25	1	14	59
216 - 7 - H	8.1	7.1	5025	40.6	15	100	1250	385	0.25	1	14	59
218 - 7 - H	9.8	8.5	4900	54.1	19	110	1250	385	0.25	1	14	59
224 - 7 - H	12.0	10.4	10130	54.1	18	135	2050	385	0.25	2	14	62
226 - 7 - H	16.0	13.9	10050	81.1	27	160	2050	385	0.25	2	14	62
228 - 7 - H	19.7	17.1	9800	108.2	36	180	2050	385	0.25	2	14	62
234 - 7 - H	17.6	15.3	15200	81.1	27	190	2850	385	0.25	3	14	64
236 - 7 - H	24.5	21.3	15075	121.7	40	220	2850	385	0.25	3	14	64
238 - 7 - H	28.9	25.1	14700	162.2	53	255	2850	385	0.25	3	14	64
244 - 7 - H	23.9	20.8	20260	108.2	35	245	3650	385	0.25	4	14	65
246 - 7 - H	32.0	27.9	20100	162.2	52	285	3650	385	0.25	4	14	65
248 - 7 - H	39.4	34.2	19600	216.3	69	330	3650	385	0.25	4	14	65
254 - 7 - H	29.5	25.7	25330	135.2	43	295	4450	385	0.25	5	14	66
256 - 7 - H	40.8	35.5	25125	202.8	65	350	4450	385	0.25	5	14	66
258 - 7 - H	49.0	42.7	24500	270.4	86	400	4450	385	0.25	5	14	66

Changes possible without prior notice



Fans

In view of its flexible construction, in principle THOR can be supplied with any desired fan.

Depending on the application there is a standard series of fans which match THOR-D perfectly.

These fans can be supplied in both blow-through and draw-through versions.

Execution

Fans are executed with balanced aluminium or polyamide fan blades, fitted with robust electrolytically galvanized and epoxy coated fan guards according to DIN 31001. Fans are mounted in vibration dampers.

Enclosed design spray-tight motors, protection class IP-55. Motor cables are lead to the outside of the cooler casing.

All motors, with the exception of the 0.18 kW, 230/50/1 motor, are equipped with a thermal safety device built in the windings, connected to separate terminals in the box.

This safety device can therefore be integrated into the control circuit. The electrical control should be arranged preferably with a manual reset device in order to prevent continuous on/off switching (tripping) of the motors. Cable inlet rages from 7 up to 12 mm.

Air throw

Air throws as given in the tables are for ceiling mounted coolers at $t = 20\text{ °C}$, an unrestrained air flow in the cold room and a minimal air velocity of 0.25 m/s at air throw distance.

Air throw values in the tables are single sided values.

Please keep in mind that TYR-D coolers are designed for dual air discharge, so cold air is discharged at the given air throw distance to both sides of the cooler.

Sound pressure dB(A)

Sound pressure as given in the tables are sound pressure levels in dB(A) according to EN 13487 at 5 m distance in free field conditions. Values may deviate depending on situations at site. The table below gives calculated sound pressure corrections at various distances.

Distance m	Correction dB(A)
1	+ 14
2	+ 8
3	+ 4
4	+ 2
5	0
10	- 6
20	-12
50	-20

Fans 50 Hz

Fan motor W	Motor voltage* V	Electric capacity		Adj. values overload relays			Cable inlet
		nom. kW	abs. kW***	A			
0 °C -20 °C -40 °C							
Execution H, nominal fan speed 1500 rpm							
250	230/400/3	0.25	0.37	1.1	1.1	1.2	2 x M20 x 1.5
220	230/1	0.22	0.37	2.6	2.8	2.9	2 x M20 x 1.5
550	230/400/3	0.55	0.70	1.7	1.8	2.0	2 x M20 x 1.5
550	230/1	0.55	0.70	5.5	6.0	6.2	2 x M20 x 1.5
1500	230/400/3	1.50	1.50	4.3	4.6	4.9	2 x M20 x 1.5
Execution L, nominal fan speed 1000 rpm							
250	230/400/3	0.25	0.25	1.1	1.1	1.2	2 x M20 x 1.5
180	230/1**	0.18	0.35	2.4	2.5	-	2 x M20 x 1.5
450	230/400/3	0.45	0.45	1.9	2.0	2.2	2 x M20 x 1.5
Execution with 2-speed fan motors, n = 1500 / 750 rpm, Dahlander connection							
370/60	400/3	0.37	0.48	1.4	1.6		2 x M20 x 1.5
		0.06	0.20	0.6	0.6		

* Motor windings 230 Volt.

** These 230/1 motors are suitable for temperatures down to -20 °C and are not provided with a thermal safety device in the windings.

*** Absorbed fan motor energy is measured in under laboratory conditions at ambient temperature 20 °C. These values may vary depending on local conditions.

Dual discharge air coolers

THOR-D



Defrost capacity

Cooler type THOR-D	Elements article number	E1		E4		
		nr of elements	cap. kW	nr of elements coil	tray	cap. kW
214	33.03.21	2	2.1	4	2	6.4
224	33.03.31	2	4.0	4	2	12.1
234	33.03.39	2	6.0	4	2	17.9
244	33.03.45	2	7.9	4	2	23.6
254	33.03.52	4	9.8	8	4	29.4
414	33.03.24	2	2.4	4	2	7.3
424	33.03.36	2	4.9	4	2	14.7
434	33.03.43	2	7.4	4	2	22.2
444	33.03.52	4	9.8	8	4	29.4
454	33.03.60	4	12.2	8	4	36.6
614	33.03.27	2	3.1	4	2	9.3
624	33.03.39	2	6.0	4	2	18.0
634	33.03.48	2	6.0	4	2	26.4
644	33.03.58	4	11.7	8	4	35.1
654	33.04.64	4	14.6	8	4	43.8
216	33.03.21	2	2.1	4	2	6.4
226	33.03.31	2	4.0	4	2	12.1
236	33.03.39	2	6.0	4	2	17.9
246	33.03.45	2	7.9	4	2	23.6
256	33.03.52	4	9.8	8	4	29.4
416	33.03.24	2	2.4	6	2	9.8
426	33.03.36	2	4.9	6	2	19.6
436	33.03.43	2	7.4	6	2	29.6
446	33.03.52	4	9.8	12	4	39.2
456	33.03.60	4	12.2	12	4	48.8
616	33.03.27	2	3.1	6	2	12.4
626	33.03.39	2	6.0	6	2	24.0
636	33.03.48	2	6.0	6	2	35.2
646	33.03.58	4	11.7	12	4	46.8
656	33.04.64	4	14.6	12	4	58.4
218	33.03.21	2	2.1	6	2	8.4
228	33.03.31	2	4.0	6	2	16.2
238	33.03.39	2	6.0	6	2	24.0
248	33.03.45	2	7.9	6	2	31.7
258	33.03.52	4	9.8	12	4	39.2
418	33.03.24	2	2.4	8	2	12.2
428	33.03.36	2	4.9	8	2	24.6
438	33.03.43	2	7.4	8	2	37.0
448	33.03.52	4	9.8	16	4	49.0
458	33.03.60	4	12.2	16	4	61.0
618	33.03.27	2	3.1	8	2	15.5
628	33.03.39	2	6.0	8	2	30.0
638	33.03.48	2	6.0	8	2	44.0
648	33.03.58	4	11.7	16	4	58.5
658	33.04.64	4	14.6	16	4	73.0

Defrost Systems

Several forced defrost systems are available. Each defrost system is optimised for specific applications and ambient conditions.

Electric Defrost (E)

Stainless steel heater elements placed in additional tubes between the evaporator tubes. The elements for the driptray are fitted to the bottom of the inner tray. Both coil and driptray have the same elements.

Standard voltage per element 230 V.

Connection to 230 V / 1 phase or 400 V / 3 phase, connected in star with Zero-Wire.

Total defrost power is given for 400 V / 3 phase with Zero-Wire.

All elements can be withdrawn at the refrigerant connection side. The driptray elements can be taken out after removal of the outer tray. The heater elements are pre-wired and are connected to one or more terminal boxes.

Depending on the ambient temperature and air humidity a number of E-executions are available.

E1 *Air on temperature down to - 25 °C.*
Electric stainless steel defrost elements in the driptray. For use in combination with for example hot gas defrost in the coil block.

E1 + I 3 *Air on temperature down to - 35 °C.*
E1, additionally equipped with an insulated double driptray. Recommended for general use in the low-temperature region.

E4 *Air on temperature down to - 5 °C.*
Electric stainless steel defrost elements in the coil block and driptray, low duty.

Hot Gas Defrost (G)

The driptray can be fitted with a defrost coil (G) to bring it rapidly up to temperature by means of hot gas.

The following G-system is available :

G1 *Air on temperature down to - 5 °C.*
Defrost coil under the coil block.

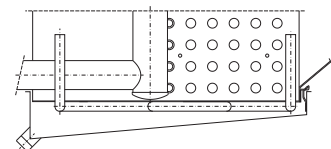

Hot Glycol Defrost (HW)

HW1 Hot glycol defrost in coil and driptray.
High temperatures.

HW2 Hot glycol defrost in coil and driptray.
Low temperatures.



Dimensions

Cooler model THOR-D	Dimensions (mm)								
	A	B	C1	C2	C3	C4	C5	D1	D2
21*	1250	385	800					625	
22*	2050	385	1600					1025	
23*	2850	385	2400					1425	
24*	3650	385	1600	1600				1025	1600
25*	4450	385	2400	1600				1425	1600
41*	1450	485	1000					725	
42*	2450	485	2000					1225	
43*	3450	485	2000	1000				975	1500
44*	4450	485	2000	2000				1225	2000
45*	5450	485	2000	1000	2000			1475	2500
61*	1650	585	1200					825	
62*	2850	585	2400					1425	
63*	4050	585	1200	1200	1200			1025	2000
64*	5250	585	1200	2400	1200			1325	2600
65*	6450	585	1200	1200	1200	1200	1200	1475	3500

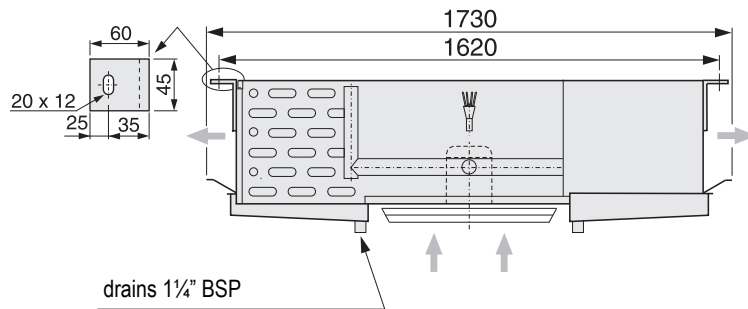
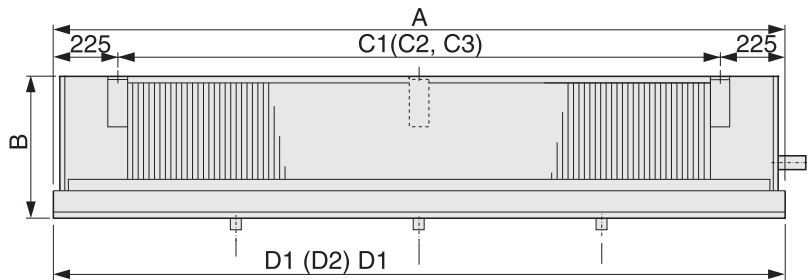

Alfa Laval in brief

Alfa Laval is a leading global provider of specialized products and engineered solutions.

Our equipment, systems and services are dedicated to helping customers to optimize the performance of their processes. Time and time again.

We help our customers to heat, cool, separate and transport products such as oil, water, chemicals, beverages, foodstuffs, starch and pharmaceuticals.

Our worldwide organization works closely with customers in almost 100 countries to help them stay ahead.

How to contact Alfa Laval

Up-to-date Alfa Laval contact details for all countries are always available on our website at www.alfalaval.com